

Instruction Manual for Bausch & Lomb "Criterion 4000" Telescope and Telephoto Lens

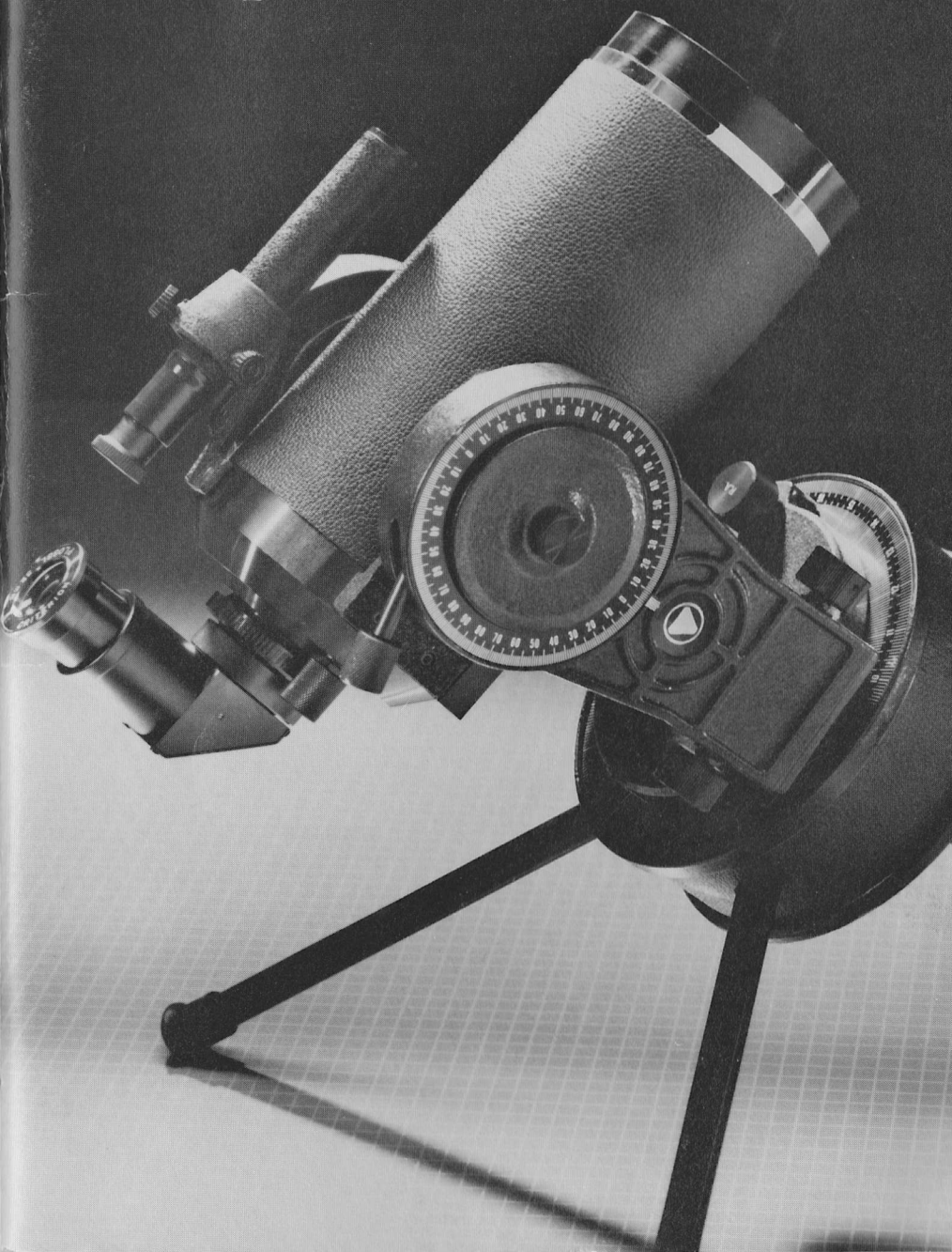

A Message to Criterion Owners from Dr. Isaac Asimov.

Astronomy is the oldest of the sciences and, visually, the most beautiful. What is more, it is the only science to which the amateur can make useful contributions. The professional, lost in astrophysics and cosmology, leaves it to the amateur to spot new comets, asteroids, novae, to monitor changes and note phenomena.

With the kind of equipment described in this instruction book, the night is yours, with wonder and beauty invisible to the eyes alone. And along with that, there is the chance of contributing to human knowledge. Where else and how else can you get so much for so little.

Isaac Asimov

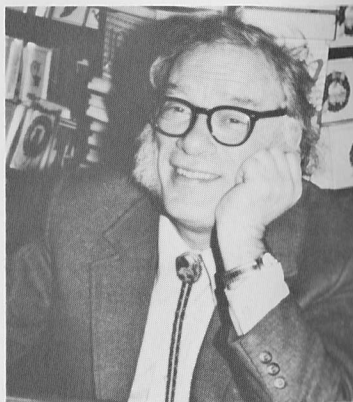

Table Of Contents

	Page
Telescope In Case	2
Identification Of Parts	3
Your First "Look"	4
Starting Sky Observing	5
Latitude Legs And Motor Drive	6
Polar Alignment	7
The Setting Circles	10
Observing The Planets	11
Observing The Moon	12
Atmospheric Disturbance	12
Using A Tripod	12
Attaching A Camera Body	12
Astrophotography	15
The Optical System	16
Care Of Fine Optics	17
Optical Alignment	18
Brake Lever Adjustment	20
Recommended Reading	21
Warranty	21
Latitudes Of Some U.S. Cities	22

Bausch & Lomb "Criterion 4000" Telescope and Telephoto Lens

Telescope in Case

You are about to enjoy the fascinating world of astronomy, high power celestial and terrestrial viewing, and a totally new aspect of photography. By reading these instructions, you will insure your investment in this remarkable instrument. Moreover, you will be able to put it to use without "false starts" and most important, without damaging its ultra fine optical and mechanical components.

On page 21 is a list of recommended periodicals and books helpful to the novice as well as the experienced amateur astronomer. Further, we urge you to contact the amateur astronomical society nearest you, because a major part of their function is to aid the beginner. The staff of a nearby planetarium or an astronomy instructor at the high school or college in your vicinity should be able to put you in touch with an amateur association.



Before removing the telescope from its case, please note the precise manner in which it is fitted. It should always be returned to its case in this same orientation. If condensation forms on the front lens or mechanical components, allow the moisture to evaporate before returning the telescope to its case for storage.

In tropical climates it is a good idea to store the telescope in a ventilated cabinet with a low wattage light bulb burning at all times to prevent the formation of mold, which can *etch glass!*

Bausch & Lomb "Criterion 4000" Telescope and Telephoto Lens

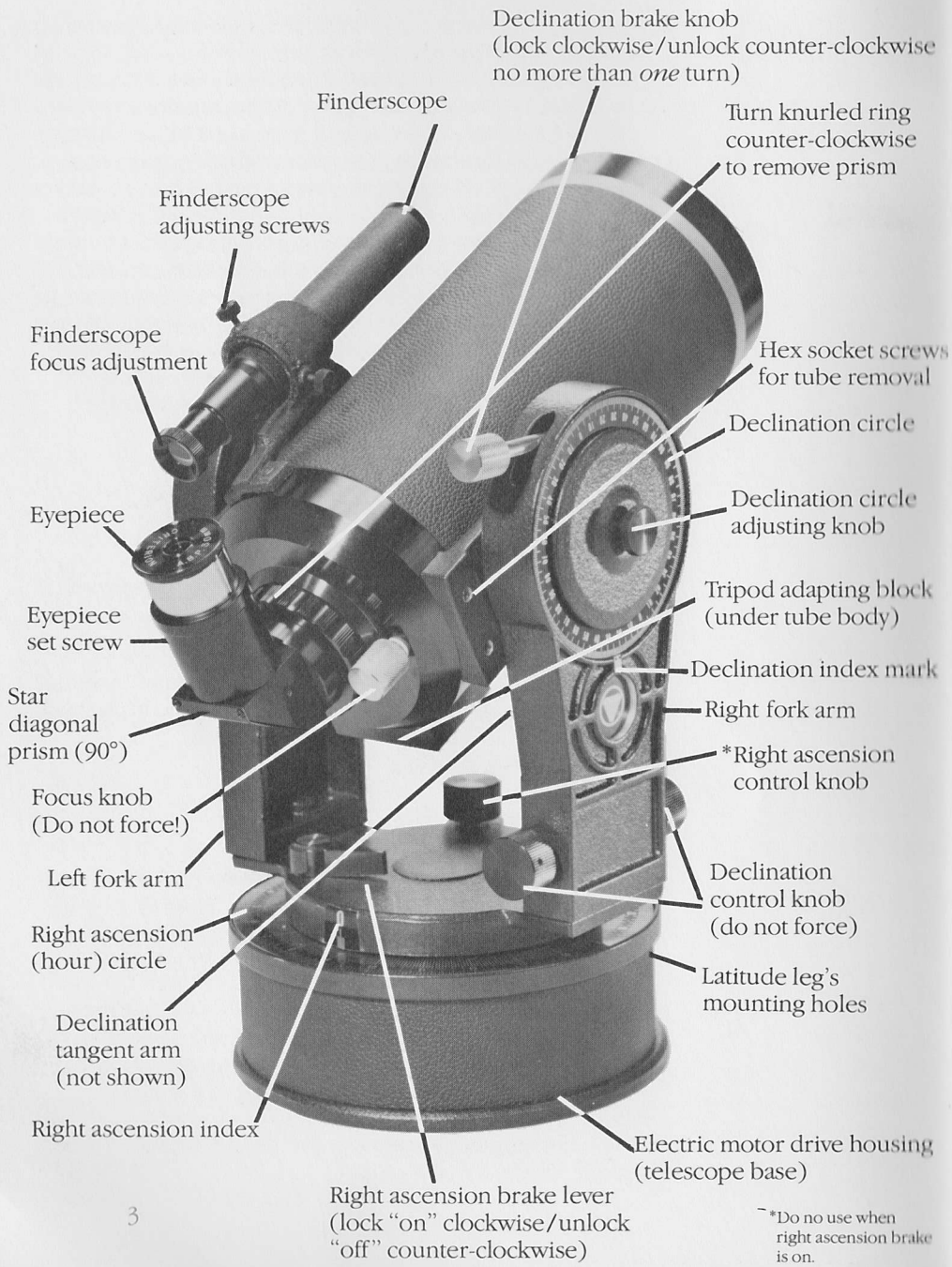

Your First Look

**Never aim
instrument
directly at the
sun, or look
through the
telescope or
finderscope
directly at the
sun, as severe
eye damage, or
damage to the
instrument can
result.**

After lifting the model 4000 from its case and removing the lens cap, carefully study the photograph which identifies all the telescope's component parts. Do not try to view through window panes, as most such glass is full of optical flaws which will degrade the telescopic image. Opening the window will solve the problem, provided the temperature is the same inside as outside. Otherwise, turbulent air currents will also ruin the image. When using the telescope outside, it must be allowed to come to the ambient temperature, at which time all the fine optical components will stabilize. In cold climates, where the inside temperatures might be in the 70s (fahrenheit) and in the 20s outside, it will take up to one hour. Conversely, the scope must be allowed to stabilize if taken from an air conditioned environment to much higher outside temperatures.

Ignoring the latitude adjusting legs and the electric cord, place the model 4000 on a sturdy table, window sill, tripod, or other rigid platform. Insert the lowest power eyepiece (40x, 30mm) into the star diagonal (lock with set screw), and by sighting along the telescope tube, (much like a rifle) locate an object, such as a building about a half mile or so away.

Slowly turn the focus knob clockwise or counter-clockwise until an image is seen. When the direction of the focus knob is reversed, a slight shift of the image will be noticed. The view will be reversed left to right. Photographically the image is not reversed.

Do not force the focus knob beyond its limits. (Depending upon atmospheric conditions, the image may or may not be very sharp.)

Now, focus the finderscope by turning its eyepiece clockwise or counterclockwise, and by adjusting the three screws, center the middle of the main telescope's image on the cross hairs of the finder. Replace the low power ocular with the high power (67x, 18mm) one and further adjust the finder alignment. Using the finder, locate another object at about the same distance and you will see that object in the eyepiece of the main telescope, although an adjustment of focus will probably be necessary. Your finderscope is now aligned with the main optics of the primary telescope. At close distances, because of parallax, the image in the finder will be below

*Do not use when right ascension brake is on.

Bausch & Lomb "Criterion 4000" Telescope and Telephoto Lens

the cross hairs with respect to the view in the telescope. Realignment of the finder will be required from time to time. Practice locating objects near and far.

Because of the unique model 4000 optical system, your telescope also functions as a long-distance microscope! Focus on a dollar bill at 20 feet or so and you will be startled at the visible detail. In fact, you will see more clearly at 20 feet that which you can see at 20 inches. Now look at spiders, flowers, birds, and a host of other common sights with totally new insight.

It is important to remember that the quality of the image seen is dependent upon atmospheric conditions. If you are using the telescope at ground level to view an object also at ground level, you might notice that the image wavers as though water is being poured over the front lens. This phenomenon occurs because heat is rising from the ground surface and disturbs the air, and is particularly noticeable if the instrument is used on an asphalt surface.

Starting Sky

Observing

The moon is the first celestial object that the novice should look at through a telescope. This is because it is large, very bright, easy to find and a very beautiful sight through the model 4000.

Without the latitude adjusting legs and the electrical power cord, place the instrument on a firm mounting. This is known as the alt-azimuth position. Locate the moon in the finderscope and if its alignment has not been disturbed you will see the moon in the eyepiece of the main telescopic assembly. If you have been observing nearby terrestrial objects, you will have to refocus by turning the focus knob counter-clockwise a considerable amount. If you have been observing distant terrestrial objects, a slight adjustment is all that is required.

As you observe the moon, you will notice that it will drift across the field of view and, in time, disappears entirely. This happens, of course, because the earth rotates. To keep the moon centered in the field of view, periodically turn the right ascension (east-left/west-right) knob in a clockwise manner using your left hand (be certain that the right ascension brake lever is OFF) and after having turned the *declination* brake to its "on" (clockwise) position, periodically adjust the declination (north-up/south-down) knob with your right hand. Before observing, make certain that the tangent

arm of the declination control is centered with respect to its forward/reverse travel. *Never force the declination Fine Control when it has reached its limits.*

It will be readily apparent that this is a most awkward manner in which to observe celestial objects. The Astro Model 4000's latitude adjusting legs and built-in electric motor drive will correct this situation.

Latitude Legs

And Motor

Drive

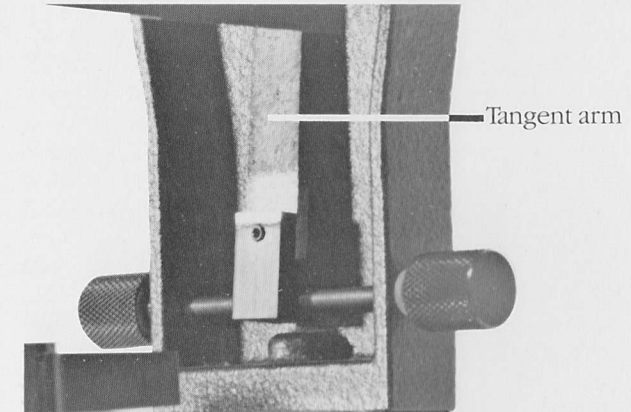

Thread the two nonadjustable latitude adjusting legs into the base side of the instrument after unscrewing the hole plugs. Now thread the *adjustable* leg into the center hole of the base plate. Place the telescope and its legs on a firm, flat surface. Set the telescope tube so that the declination circles read 90° and locate the North Star in the finderscope by shifting the legs east to west and by sliding the adjustable section of the center leg until the North Star is centered on the cross hairs. Locate the North Star in the eyepiece of the main telescope and make further adjustments until the North Star is centered within the field of view.

Your telescope is now "polar aligned". This means that the axis about which the telescope revolves in right ascension (east to west/left to right) is essentially parallel to the axis of the earth's rotation (see photo, page 7).

For observers in the Northern Hemisphere, most of the interesting celestial objects will be seen from overhead and toward the South. (All sky objects are best viewed when they appear on or near the meridian — the imaginary line that separates East from West.) Move the telescope one-half turn in Right Ascension so that the eyepiece is pointing away from your eye. Position

The Model 4000 in "Polar Alignment"

The Constellation Big Dipper is shown in its seasonal positions. The two stars at the end of the bowl point almost exactly to the North Star.

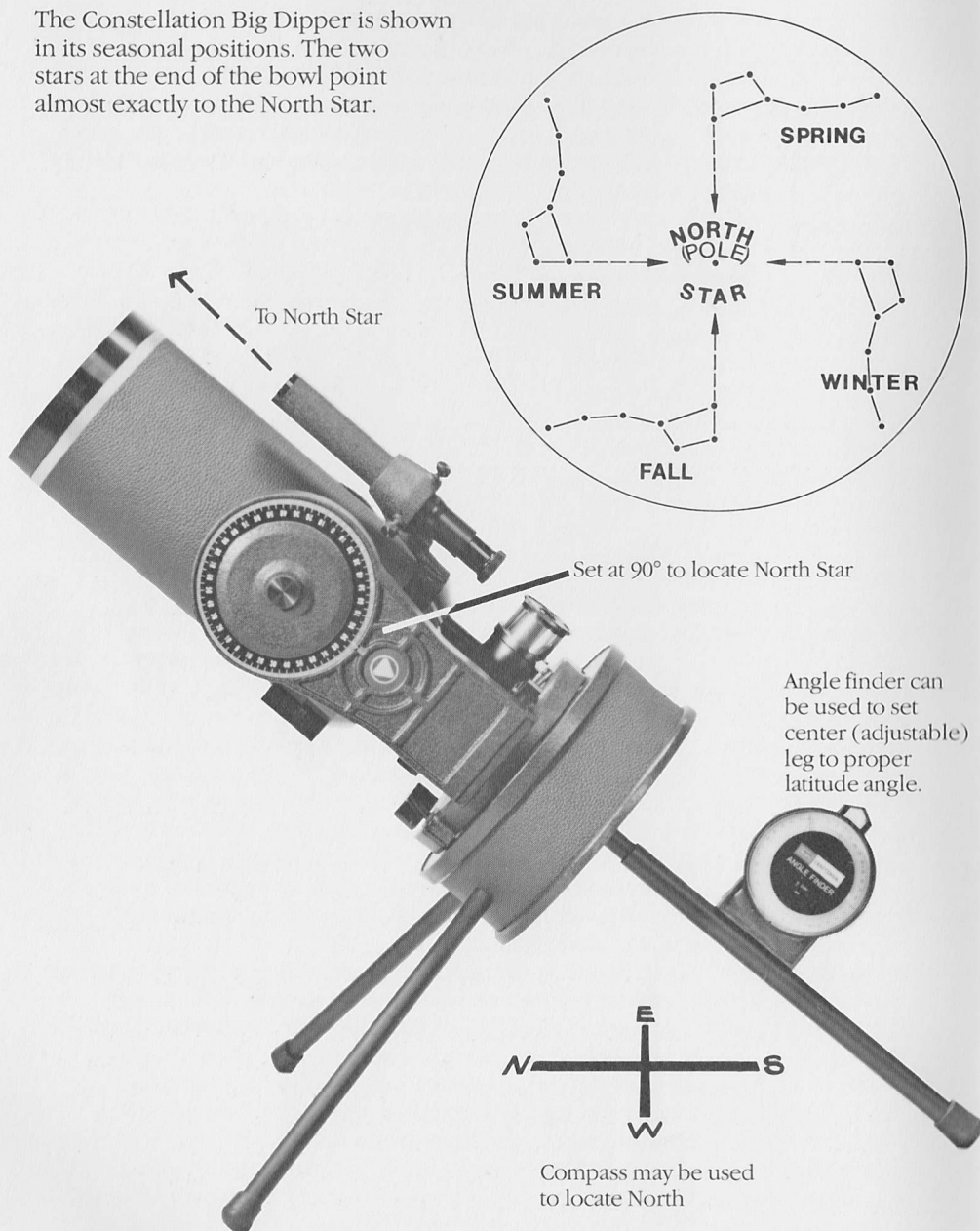

Bausch & Lomb "Criterion 4000" Telescope and Telephoto Lens

yourself so your back is toward North. Unlock the declination brake and swing the telescope tube away from you (South). Locate the moon in the finder and then in the main telescope. By occasional clockwise movements of the right ascension control knob, the moon can be kept centered within the field of view of the telescope's eyepiece for as long as desired.

This, however, is not enough luxury for the model 4000. Therefore, we have incorporated an electric motor drive which will automatically compensate for the earth's rotation. Attach the supplied electric power cord into the base of the instrument and plug the male fitting into a standard 110 volt 60 hrz. outlet. Turn the right ascension brake "ON" (clockwise) and the telescope will now "track" the moon, stars, and planets.

NOTE:

If the North Star cannot be seen because of an obstruction, the use of a compass and an "Angle Finder" (available from Sears Roebuck) will facilitate polar alignment. Locate North with the compass (call nearest airport to determine local variation in compass reading), and orient the model 4000 as shown on page 7. Using the Angle finder, set the adjustable center leg so that the angle reads the same as your latitude. Most maps have latitude readings on right and left margins. Latitudes for many U.S. cities are listed on page 22.

The telescope is now fairly well aligned in order to follow the motions of most celestial objects. It is unlikely, however, that the polar alignment is absolutely accurate.

If, for instance, the moon appears to drift northward (upward) in the eyepiece of the telescope, the latitude adjusting legs on the firm platform should be adjusted slightly clockwise (as you look down upon the instrument) in small increments until the northward drift is eliminated.

Conversely, if the drift appears to be in a southerly (downward) motion, reorient the telescope in a counter-clockwise motion. Once you have obtained stability in tracking a celestial object, and if you are using a permanently mounted observing platform, mark the position of the three legs on the observing surface and using a pencil mark the position of the adjustable latitude leg.

If you travel with your instrument, and we hope you will, it will be necessary to repeat this procedure. When placed in the forward hole on the bottom plate, the adjustable center leg will provide latitude adjustments from approximately 35 to 50 degrees latitude, in the center hole from approximately 30 to 40 degrees, and in the rear hole, 25 to 35 degrees. This will apply to positions north and south of the Equator.

NOTE:

The electric drive system in the model 4000 is designed to offset the rotation of the earth which turns once in 24 hours about its own axis. Because of this very slow rotational mode, do not expect to see an apparent motion of the telescope. Remember, the telescope turns about its own axis once in 24 hours. This means it travels at half the rate of the hour hand on your normal 12 hour reading clock. Should you have any doubts about the motor-drive operating, place your ear to the telescope base and you will hear the electric motor running. The right ascension brake lever must be locked "on" for the electric drive to function. Further, locate a celestial or terrestrial object in the field of view of the main optical system and turn the motor on by plugging in the electric cord. If observing a celestial object, according to the

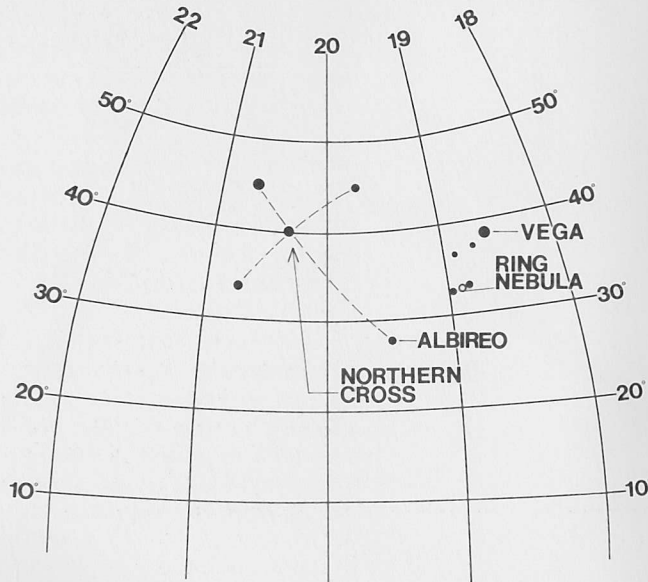

previous instructions, the object will stay within the field of view. By following the above when observing a terrestrial object, you will note that the object moves from the field of view.

The Setting Circles

The function of the "mysterious" setting circles is to assist you in locating dim celestial objects. Just as the earth is divided into a grid pattern of latitudinal (north/south) and longitudinal (east/west) sections, so is the sky. In the heavens, latitude corresponds with declination (north/south) and longitude corresponds with right ascension (east/west). Just as every point on earth has a specific latitudinal and longitudinal "address" (New York city's address is 40 degrees, 45 minutes north latitude, 74 degrees west longitude) so does every star in the sky have a specific location in terms of declination and right ascension.

For instance, if we look directly overhead when darkness falls on a September evening from a northern latitude, we will see the bright star Vega, which is located in the constellation Lyra. Referring to a star chart, we find that Vega's address is plus (north) 38 degrees, 36 minutes declination, and 18 hours, 36 minutes right ascension.

With your telescope properly polar aligned, locate Vega in the finder telescope and then in the main telescope. You will find that your declination circle will read close to 38 degrees, 36 minutes north. With the telescope motor running and the right ascension brake lever in the "on" position, move the right ascension circle with your thumbs until the 18 hour, 36 minute position on the circle is lined up with the index. (Each division of the right ascension circle is equal to 4 minutes.) Your telescope is now "in step" with the sky.

You can locate any object in the sky if you know its declination and right ascension coordinates.

Within the constellation Lyra is the famous Ring Nebula which resembles a faint smoke ring. This object is the outer shell of a collapsed red giant star. Its coordinates are plus (north) 33 degrees declination and 18 hours 53 minutes right ascension. Unlock the declination brake and move the barrel of the telescope until the declination scale reads plus 33 degrees. Lock the declination brake in this position and make further adjustments with the fine control if necessary. Next, unlock the right ascension brake and without

touching the right ascension circle, move the telescope until the index is positioned at 18 hours 53 minutes, and lock the right ascension brake lever.

If your telescope is perfectly polar aligned, the Ring Nebula will be within the field of view of the eyepiece. (Always use the lowest power eyepiece to locate an object.) The chances are that the Ring Nebula may not be within the field, but it will be close. By making slight adjustments in right ascension and declination, a "grid" search will locate the object in a short period of time. Nearby in the sky (relatively speaking) will be found the Northern Cross section of the constellation Cygnus. The name of the southern most star in the Northern Cross is Albireo. Using the above procedures, locate Albireo whose coordinates are plus 27 degrees, 54 minutes declination, 19 hours 30 minutes right ascension. You will find that Albireo is not one but *two* stars. A beautiful blue and gold pair.

At this point you have located Vega which is the fifth brightest star in the sky, the Ring Nebula (a favorite of amateur astronomers), and the beautiful double-star Albireo.

With a little bit of practice, you will master the locating of "fixed" objects. Some objects do not have a permanent "address". The planets (wandering stars), the moon, the sun and comets have constantly changing positions with respect to the stars.

NOTE: The *declination* circles are factory preset, but should their settings be disturbed, they can be reset by using a level or angle finder. Place the telescope base on a level surface and swing the telescope tube to its level position. The length of the tube will now be parallel to the level surface. Lock the declination brake and further adjust the leveling of the telescopic tube using the fine declination control knob. On either the right or left fork arm, loosen the declination setting circle by turning its locking knob slightly counter-clockwise and rotate the declination circle until the number zero is centered at the declination index mark. Turn the knob clockwise to lock the circle in position and then repeat this procedure for the opposite fork arm declination setting circle.

Observing

The Planets

Observing

The Moon

Atmospheric

Disturbance

The published monthly astronomical journals (see page 21) give the specific locations of the various planets with respect to the stars. Mercury, the innermost planet, will appear as nothing more than a bright "star" in a small telescope. Venus, the second planet out from the sun, will reveal little detail except for its ever changing phases like that of our moon. Mars, the fourth planet from the sun (our earth is the third), will, at favorable times, show us surface detail and polar ("snow") caps. Jupiter, the largest planet in our solar system, which resides approximately 1/2 billion miles away from us, will display everchanging surface details. In addition, we can observe the changing positions of its four brightest moons. At about 1 billion miles away, Saturn, will show its ring system and will make an indelible impression upon the observer. The planets beyond Saturn are too small, faint, or far away to be of interest to the casual observer.

The moon is such an obvious object in the sky that it can be readily located in the telescope. Surface detail is best observed when the moon is in its crescent phases as opposed to its full or nearly full status. The separation of light from darkness accentuates surface detail. With the use of a lunar map, (see page 21) you will be able to locate and identify specific craters, maria ("oceans"), mountains and valleys. Like the joy of music where one recognizes the selection and composer, so it is with the moon. To identify the various lunar features renders a sense of fulfillment and identity. The full or nearly full phase of the moon is wonderful for emotionally entwined couples, but is not exciting for the astronomer. First, its brightness obliterates surface detail and "washes out" most of the other objects in the sky. Further, its brightness is disturbing (*not harmful*) to the eye.

Generally speaking, because of atmospheric disturbance, no object in the sky is worth viewing if it is less than 30 degrees above the horizon. Viewing straight overhead penetrates approximately 10 miles of the earth's atmosphere, viewing horizontally *attempts* to penetrate one hundred miles of disturbance.

When the stars are "twinkling" rapidly, the "seeing" is poor as the twinkle is caused by small, rapid movements of the air. When the air is moving like this, no detail can be observed as the image is "smeared."

Bausch & Lomb "Criterion 4000" Telescope and Telephoto Lens

Using a Tripod

When using the telescope away from a permanent stable platform, it is not always practical to use the latitude adjusting legs. A very sturdy tripod with adjustable panhead is a practical necessity for these occasions. In lieu of the latitude adjusting legs, the telescope may be attached to a tripod by virtue of its 1/4 x 20 threaded holes in the base plate. Apply all the aforementioned procedures of the latitude adjusting legs to the tripod's panhead to achieve polar alignment.

Attaching a Camera Body

Both versions of the model 4000 can accommodate virtually all 35mm single lens reflex camera bodies which are equipped with a focal plane shutter and a removable lens. All that is required is the cassegrain focus adaptor (supplied with the telephoto version) and a T-ring adaptor for the specific camera being used. On the astro model, it is necessary to remove the star diagonal prism from the rear of the telescope tube by unscrewing the large knurled ring counterclockwise.

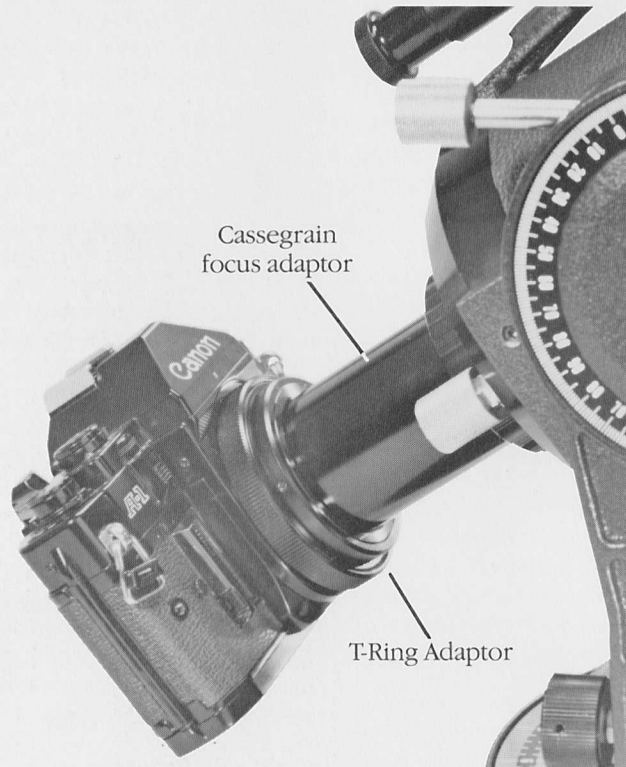

When the camera body is attached to the telescope, the latter becomes a 1200mm F/12 telephoto lens. To determine proper exposures for terrestrial subjects, set the camera film speed dial to the ISO (ASA) rating of the film being used. Locate and focus on the subject to be photographed and utilizing your camera's built-in light metering system, adjust the shutter speed until your camera indicates a correct exposure reading. Most cameras have a "stop down" meter setting which should be used for telephoto photography. Check your camera instruction manual. Because of the extremely high magnification being used, it is necessary to use a cable or preferably an air bulb shutter release mechanism. As an alternative, the camera's self-timer may be used. The use of the manual shutter release button depressed by your finger, will result in severely blurred images. If desired, series 6 filters may be placed in the recess at the rear of the telescope and held in place by the cassegrain focus adaptor.

The tube assembly on both versions has a tripod block attached to its rear underside. When using the astronomical version for terrestrial photography, the tube assembly may be removed from the base fork arms by simply removing the four hex screws (two on each side) with the supplied hex wrench.

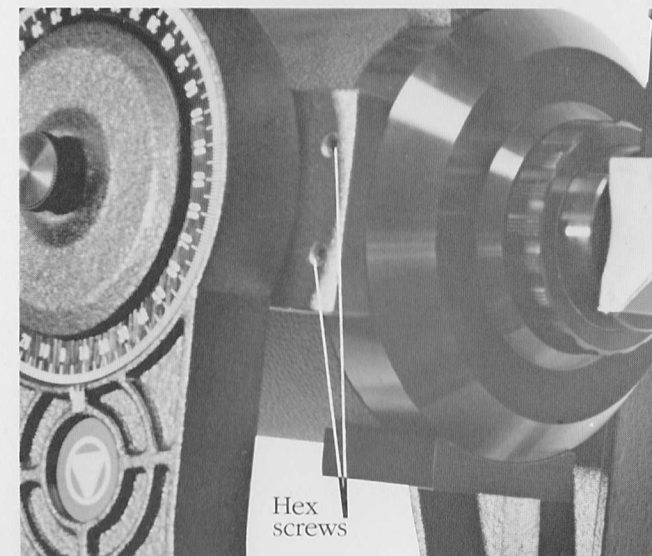

Bausch & Lomb "Criterion 4000" Telescope and Telephoto Lens

The telescope lens may now be attached to any sturdy tripod panhead. In all telephoto photography it is wise to "bracket" your exposures. That is, if the camera's meter indicates an exposure of 1/125 second exposure time, take one photograph at 1/60, one at 1/125 and one at 1/250. Keep a record of your exposure times and when you have the final results, you will be able to determine the characteristics of your camera's meter. Remember that vibration from any source is likely to prevent sharp images from being formed. Gusts of wind are particularly offensive. Don't be discouraged if your first efforts are not what you hoped for — experience is the greatest instructor.

Astronomical photography is a very complex subject; however, photographing the moon is relatively easy and it is the best subject for the beginning astrophotographer to start with. Using ISO (ASA) 400 speed film, the full moon, *high in the sky*, requires an exposure time of approximately 1/250 of a second. Because this is virtually a "snap shot" it is not necessary to utilize the driving mechanism, although it is a great convenience. Photographing a quarter moon requires an exposure time approximately 4 times longer or 1/15 second. At this relatively slow exposure time, it is wise to employ the electric drive of the astronomical version to better insure a sharp image. Depending upon the density of the pollutants in the atmosphere, these exposure times are approximate. Once again, it is wise to bracket the exposures. The 1200mm focal length of the model 4000 will produce a lunar image size of approximately 12mm in diameter (about 1/2 inch). If your camera has a center-weighted light metering system, it is possible to determine shutter speeds using the meter. (A right-angle viewing attachment for your camera is a convenience for astrophotography.)

Photographing crater detail (and the planets) requires the use of the optional eyepiece-projection tube. This accessory permits an eyepiece to be placed between the camera body and the telescope, projecting the telescopic image onto the film plane. This method vastly increases

Astro- photography

the effective focal length of the system. The following table lists the approximate effective focal lengths and F ratios with varying eyepieces.

50mm eyepiece — 3,360mm (F/33)
30mm eyepiece — 5,600mm (F/56)
18mm eyepiece — 9,300mm (F/93)
12.7mm eyepiece — 13,200mm (F/132)
9mm eyepiece — 18,600mm (F/186)

Because of these extremely high magnifications, it is essential that there is no vibration and that the air is still.

It is important to know that the higher the F ratio, the longer the exposure time required. For instance, if a given object being photographed at F/12 requires an exposure of 1/1000 second, F/33 requires 1/125, F/56 1/60, F/93 1/15, F/132 1/8 and F/186 1/4 second. The utilization of a 9mm ocular is about the practical photographic limit for the model 4000. With increasing effective focal lengths, the image becomes increasingly dimmer and consequently more difficult to focus.

When the power is doubled photographically or visually, one-fourth the light reaches the film plane or the eye. The field of view is also narrowed by one-half.

This instrument is a Schmidt-Cassegrain telescope, which produces sharper images over a wider, flatter field than any other telescope design.

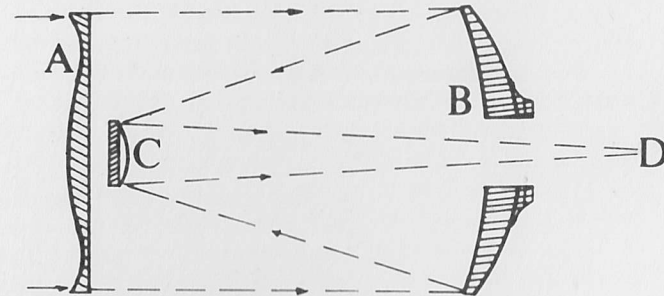

Light enters the optical system through the corrector plate (A), is collected by the concave spherical mirror (B), is reflected to the small convex mirror (C) and is reflected through a hole in the primary mirror to point (D) where the image is formed. This point is known as

The Optical System

the Cassegrain focus and the formed image is often referred to as the "real" image. The star diagonal prism deflects this light 90 degrees upward for viewing comfort. The use of an eyepiece permits a high power examination of the "real" image.

The degree of magnification that can be employed depends upon the quality and the brightness of the real image. A rule of thumb tells us that the upper limit of magnification in a telescope is 60x per inch of diameter of the telescope lens; however, a more realistic limit is 50x, thus using a 6mm eyepiece will provide 200x and under ideal atmospheric and lighting conditions, we can expect to use this maximum power.

We can determine the power being delivered by any eyepiece by dividing its focal length into the focal length of the telescope. To calculate the power produced by a 6mm eyepiece, divide the 1200mm focal length of the model 4000 by 6mm and we find that this combination produces 200x. The highest powers can be successfully utilized on very bright terrestrial objects, the moon and occasionally the brighter planets. When viewing dim objects in the sky, such as the Ring Nebula, the lower power eyepieces will serve us better because the image will be brighter and have more contrast. The selection of which eyepiece to use on varying objects will be determined by experience.

Exceeding the upper power limitations of any telescope will result in what astronomers call "empty magnification". This simply means that although an image may appear larger, it has lost contrast and sharpness of detail.

The front Schmidt corrector lens of the model 4000 is coated with magnesium fluoride to increase light transmission and to enhance contrast. Improper and frequent cleaning of this element will soon degrade its performance. Our natural tendency toward cleanliness should be subdued. Although a thin layer of dust may offend one's sensibilities, it has virtually no effect on the instrument's performance.

When it becomes absolutely necessary to clean the front lens, it is imperative that these instructions be followed: First, using a squeeze bulb blower (sold in most camera stores) remove as much dust and dirt as

possible. Next, take a fine camel's hair brush and gently stroke off the remainder. Now take a piece of soft, fresh cotton slightly dampened with Windex and very gently stroke the surface of the lens while constantly rotating the cotton. Change the cotton often so as to avoid using its surface for more than one stroke. Following this procedure, gently breathe on the lens which will leave a layer of moisture (distilled water) and gently polish the surface with dry cotton. *Never* deviate from this procedure and *never* use eyeglass cleaning tissues.

The front lens of the finder scope, its eyepiece and all other eyepieces may be cleaned by breathing on their surfaces and gently wiping with soft, clean cotton.

So long as the rear opening of the main optical tube is kept covered, internal cleaning of the optical elements should never be necessary. Should condensation form on the interior optical surfaces, bring the telescope into a warm area, uncover the rear hole and allow the moisture to evaporate. If, in time, it appears that the internal optics must be cleaned, consult the Bushnell division of Bausch & Lomb for instructions.





Optical

Alignment

The corrector lens and the primary and secondary mirrors of your model 4000 were precision aligned at the factory and should never need readjusting unless the instrument has been subjected to severe shock or prolonged vibration. Only the secondary mirror can be moved out of alignment. To check collimation, locate a bright star high in the sky using the 30mm eyepiece. (Be certain that your telescope has reached the ambient temperature as previously discussed.) Defocus the star image until the resultant circle of light is expanded to approximately one-quarter of the field of view, and study this out-of-focus circle carefully. If the instrument is properly collimated, the black inner shadow of the secondary housing will appear perfectly centered within the out-of-focus circle as in figure A. If this shadow is not concentric with the out-of-focus circle as in figure B, your instrument is in need of collimation.

Care Of Fine

Optics

	OUT OF FOCUS	IN FOCUS
Figure A Properly Collimated System		
Figure B Out of Collimation		

CHECKING COLLIMATION — To check the collimation of your Model 4000 defocus a bright star image. If the out of focus circle appears as in Figure B, the instrument is in need of collimation.

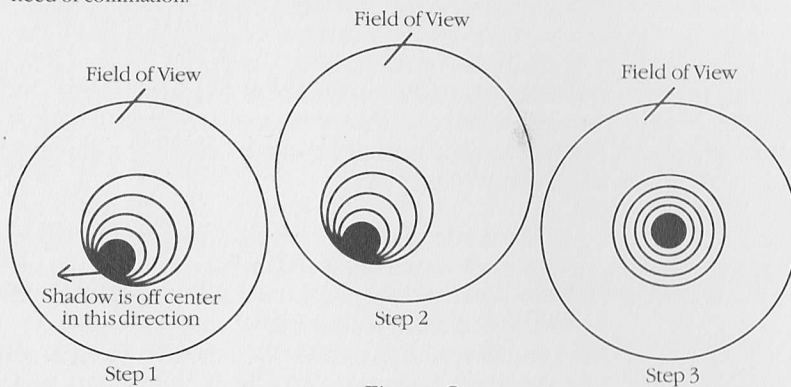
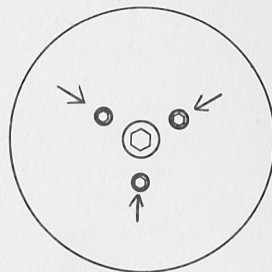

Figure C

Step 1 — Determine the direction towards which the inner shadow is off center.
 Step 2 — Using the R.A. and DEC. controls, move the out of focus circle to the edge of the field of view in the direction that the shadow is off center.
 Step 3 — Adjust the 3 screws on the secondary holder until the out of focus circle is brought back to the center of the field. Repeat Steps 1-3 if necessary.

Figure D



Illustrates the appearance of the front secondary holder. The arrows indicate the proper screws to adjust in Steps 1-3 above.

To recollimate the instrument, look through the 30mm eyepiece at the out-of-focus circle and carefully determine the direction towards which the shadow is off-center. Using the controls to move the out-of-focus circle in the direction that the shadow is off, center until the out-of-focus circle is on the edge of the field of view (see figure C). Now make very fine adjustments of the three screws on the outside of the secondary mirror's housing until the out-of-focus image is brought back to the center of the field (see figure D). *Never* attempt to adjust the central screw of the secondary housing. Adjustment of the secondary screws is extremely sensitive. *Use only small fractions of a turn* on each screw and observe the effect on the image after each adjustment. *Do not force* the screws or permanent damage may result. They should only be tightened to a "snug" tightness.

If one screw becomes too tight during adjustment, loosen the other two. Conversely, if one screw becomes too loose, tighten the other two. Repeat the collimation procedure using your 30mm eyepiece until the out-of-focus circle is perfectly concentric with the inner shadow of the secondary housing as shown in figure A. As a final check, replace the 30mm eyepiece with your highest power eyepiece and check the collimation again. If necessary, repeat the collimation procedure with the high power.

Brake Lever

Adjustment

The right ascension brake is factory set to give a firm braking action and should rarely need readjustment. If after much use, the braking action decreases and some slippage is noticeable, there is a simple provision for adjustment. You will note a set screw on one side of the plastic brake lever. Loosen this screw and draw the lever off. Then tighten the remaining socket cap screw down with a hex wrench to the tightness desired. Be careful not to over tighten or the brake lever will not completely disengage during use. Now replace the plastic cap with its lever as far over to the left as possible so that it touches the metal wall of the left fork arm. This is done to insure that you will never tighten past this point. Tighten the set screw and the brake lever will again be operable.

Recommended Reading

There are two leading monthly astronomical journals that provide current useful information on all aspects of amateur astronomy. Subscription information can be obtained by writing to:

Sky and Telescope, published by Sky Publishing Corporation, 49 Bay State Road, Cambridge, Massachusetts, 02238-1290.

Astronomy, published by AstroMedia Corporation, P.O. Box 92788, Milwaukee, Wisconsin, 53202.

The Telescope Handbook and Star Atlas by Neale E. Howard. A most comprehensive large format book dealing with virtually all aspects of telescopes and amateur astronomy, including a detailed moon map and star charts. It is available from Sky Publishing Corporation.

Astro Photography Basics (AC-48). A very helpful pamphlet, can be obtained by sending 50 cents to Eastman Kodak Company, Consumer/Professional and Finishing Markets, Rochester, New York, 14650.

Geographical Locations

Place	Latitude	Place	Latitude	Place	Latitude
Akron, Ohio	41°05'	Erie, Penna.	42°07'	Omaha, Nebraska	41°16'
Albany, New York	42 39	Eugene, Oregon	44 03	Paducah, Ky.	37 05
Albuquerque, N.M.	35 05	Evansville, Ind.	37 58	Pensacola, Florida	30 25
Allentown, Penna.	40 36	Fargo, N.D.	46 53	Peoria, Illinois	40 42
Altoona, Penna	40 31	Fort Wayne, Ind.	41 04	Philadelphia, Penna.	39 57
Amarillo, Texas	35 12	Fort Worth, Texas	32 45	Phoenix, Arizona	33 27
Asheville, N.C.	35 36	Fresno, California	36 44	Pittsburgh, Penna.	40 26
Atlanta, Georgia	33 45	Galveston, Texas	29 18	Portland, Maine	43 40
Augusta, Maine	44 19	Grand Rapids, Mich.	42 58	Portland, Oregon	45 31
Austin, Texas	30 16	Greenville, S.C.	34 51	Portsmouth, Va.	36 50
Baltimore, Md.	39 17	Gulfport, Miss.	30 22	Providence, R.I.	41 50
Bangor, Maine	44 48	Harrisburg, Penna	40 16	Racine, Wisconsin	42 44
Barrington, N.J.	39 52	Helena, Montana	46 36	Raleigh, N.C.	35 47
Baton Rouge, La.	30 27	Holyoke, Mass.	42 12	Reading, Penna.	40 20
Battle Creek, Mich.	42 19	Houston, Texas	29 45	Reno, Nevada	39 31
Berkeley, Calif.	37 52	Indianapolis, Ind.	39 46	Richmond, Virginia	37 32
Billings, Montana	45 47	Iowa City, Iowa	41 40	Roanoke, Virginia	37 16
Binghamton, N.Y.	42 06	Jackson, Miss.	32 18	Rockford, Illinois	42 16
Birmingham, Ala.	33 21	Jacksonville, Fla.	30 20	Sacramento, Calif.	38 35
Bismarck, N.D.	46 48	Jersey City, N.J.	40 44	Schenectady, N.Y.	42 49
Boise, Idaho	43 37	Johnstown, Penna.	40 20	St. Joseph, Mo.	39 46
Boston, Mass.	42 21	Kansas City, Kansas	39 07	St. Louis, Mo.	38 38
Bridgeport, Conn.	41 11	Kenosha, Wisconsin	42 36	St. Paul, Minnesota	44 57
Brownsville, Texas	25 54	Knoxville, Tenn.	35 58	Salt Lake City, Utah	40 45
Buffalo, New York	42 53	Lansing, Michigan	42 44	San Antonio, Texas	29 26
Burlington, Vermont	44 29	Laredo, Texas	27 30	San Diego, Calif.	33 43
Butte, Montana	46 01	Las Vegas, Nevada	36 10	San Francisco, Cal.	37 47
Cambridge, Mass.	42 22	Lexington, Ky.	38 03	Santa Barbara, Cal.	34 25
Camden, N.J.	39 57	Lima, Ohio	40 45	Santa Fe, N.M.	35 41
Cedar Rapids, Iowa	41 58	Lincoln, Nebraska	40 49	Savannah, Georgia	32 05
Champaign, Ill.	40 07	Little Rock, Arkansas	34 45	Seattle, Washington	47 37
Charleston, W. Va.	38 21	Los Angeles, Calif.	34 03	Shreveport, La.	32 31
Charleston, S.C.	32 47	Louisville, Ky.	38 15	Sioux City, Iowa	42 30
Charlotte, N.C.	35 14	Lubbock, Texas	33 35	Sioux Falls, S.D.	43 33
Chattanooga, Tenn.	35 03	Madison, Wisconsin	43 04	South Bend, Indiana	41 41
Cheyenne, Wyoming	41 08	Marion, Ohio	40 35	Spokane, Washington	47 40
Chicago, Illinois	41 52	Memphis, Tenn.	35 09	Springfield, Illinois	39 48
Cincinnati, Ohio	39 06	Miami, Florida	25 47	Springfield, Mass.	42 06
Cleveland, Ohio	41 30	Minneapolis, Minn.	44 59	Springfield, Missouri	37 13
Colorado Springs, Colo.	38 50	Mobile, Alabama	30 42	Springfield, Ohio	39 56
Columbia, Missouri	38 57	Moline, Illinois	41 31	Superior, Wisconsin	46 43
Columbus, Ohio	39 58	Montgomery, Ala.	32 23	Syracuse, N.Y.	43 03
Concord, N.H.	43 12	Montpelier, Vt.	44 16	Topeka, Kansas	39 03
Dallas, Texas	32 47	Nashville, Tennessee	36 10	Tucson, Arizona	32 13
Davenport, Iowa	41 31	Newark, New Jersey	40 44	Tulsa, Oklahoma	36 09
Daytona Beach, Fla.	29 13	New Haven, Conn.	41 18	Utica, New York	43 06
Denver, Colorado	39 45	New Orleans, La.	29 57	Washington, D.C.	38 54
Des Moines, Iowa	41 35	New York, New York	40 45	Wichita, Kansas	37 42
Detroit, Michigan	42 20	Norfolk, Virginia	36 51	Wichita Falls, Texas	33 55
Dodge City, Kansas	37 45	Ogden, Utah	41 14	Wilmington, Del.	39 45
Durham, N.C.	36 01	Oklahoma City, Okla.	35 28	Winston-Salem, N.C.	36 06
El Paso, Texas	31 46				

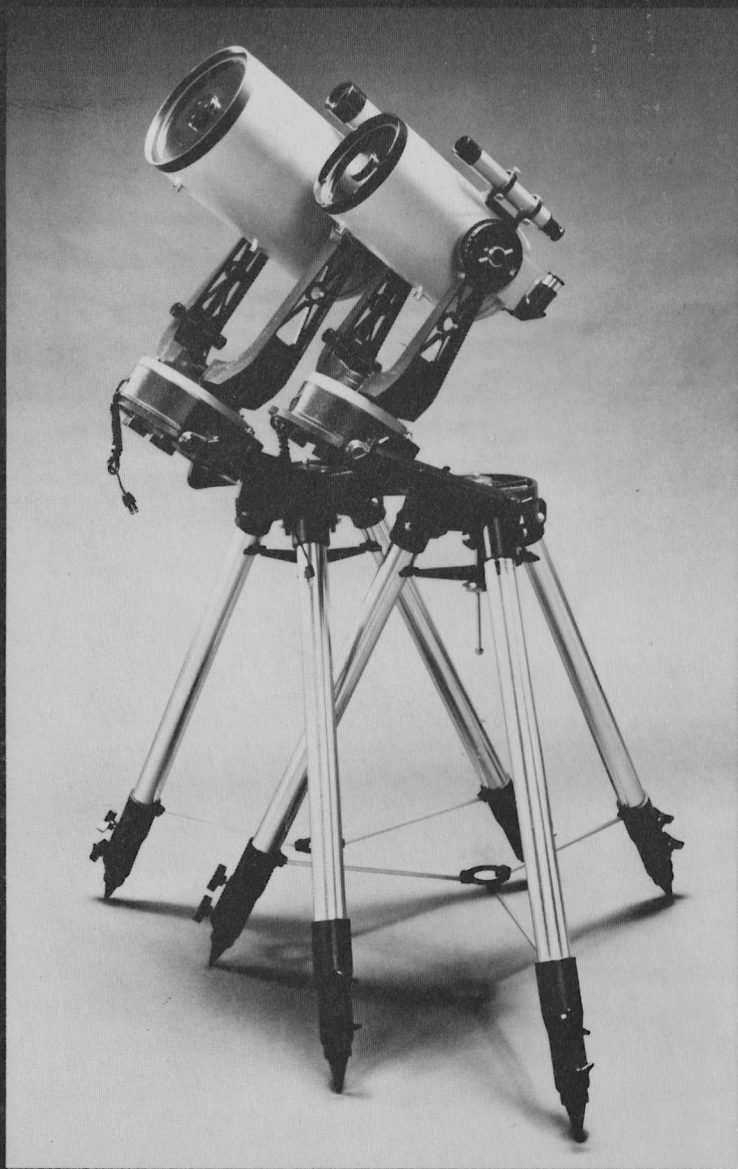

Shown above are the Bausch & Lomb Schmidt-Cassegrain 6" and 8" Telescopes and Tripods, for the ultimate in Astronomical viewing and photography.

BUSHNELL

DIVISION OF **BAUSCH & LOMB**

2828 E. Foothill Blvd.

Pasadena, CA 91107 (213)577-1500

Form No. 62-0913 1/80